

EM 80
24 Volt 56 Amps

for use with "N" serial numbers
2-year warranty

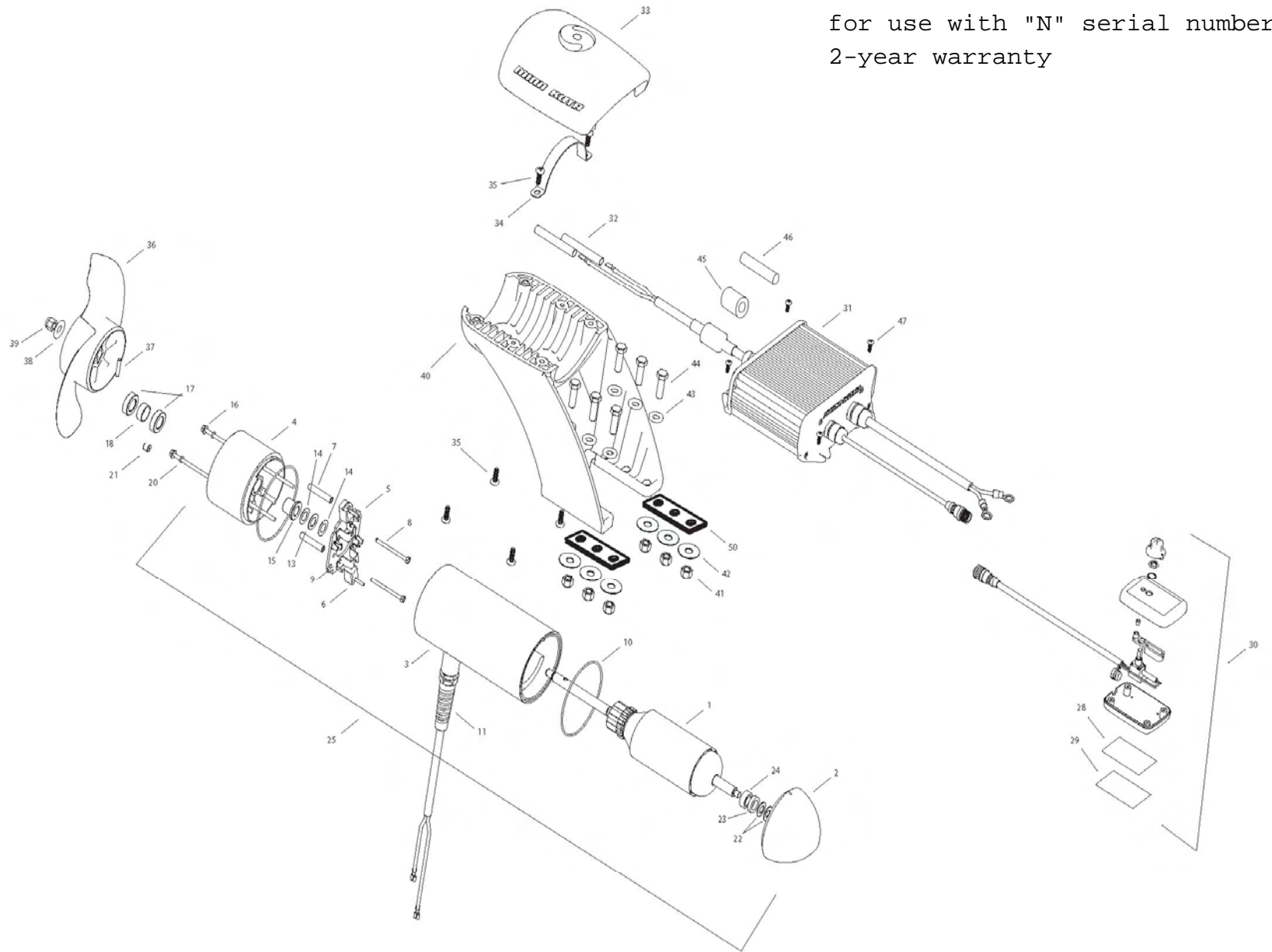

1	2-100-234	ARMATURE 24V 4.0
2	421-276	PLAIN END
3	2-200-161	CENTER HOUSING ASSEMBLY
4	2-300-149	BRUSH END HOUSING (CONTAINS 15, 17, 18, 21)
5	2-600-234	BRUSH PLATE ASSEMBLY (CONTAINS 5, 6, 9)
6	188-094	BRUSH
7	973-025	SPACER - BRUSH PLATE
8	830-027	SCREW #10-32 X 2 SLF THREAD
9	975-041	BRUSH SPRING
10	701-043	O-RING [2 EA]
11	2772917	LEADWIRE ASSEMBLY
13	990-051	WASHER STEEL
14	990-052	WASHER NYLATRON
15	144-017	FLANGE BEARING
16	830-094	THRU-BOLT 12-24 X 10.31
17	880-025	SEAL [2 EA]
18	725-095	PAPER TUBE
20	701-009	O-RING THRUBOLT
21	836-001	ALUMINUM PLUG
22	992-010	SPRING WASHER [2 EA]
23	990-045	THRUST SPACER
24	140-010	BALL BEARING
25	2396233	MOTOR ASSY 24V 4.0 80#
28	9950953	VELCRO 1.5 X 2.0 LOOP
29	9950950	VELCRO 1.5 X 2.0 HOOK
30	2990241	HAND CONTROLLER
31	2990247	CONTROL MODULE
32	2385401	SHRINK TUBE [2 EA]
33	2380210	TOP CAP
34	2383810	STRAP, EM
35	2383418	SCREW 1/4-20 SELF TAPPING [6 EA]
■	1378132	PROP KIT
36	2331160	PROPELLER
37	2262658	DRIVE PIN
38	2091701	WASHER, PROP LARGE
39	2093101	NUT, PROP
40	2381940	LOWER BRACKET
41	2383122	NUT 3/8-16 NYLOCK [6EA]
42	2381726	WASHER FENDER 3/8 X 1 1/4 OD [3 EA]
43	2381728	WASHER 3/8 [3 EA]
44	2383422	SCREW 3/8 X 1 1/4 [6EA]
45	2307310	FERRITE BEAD (EUROPEAN MOTORS ONLY)
46	2075401	HEATSHRINK (EUROPEAN MOTORS ONLY)
47	2373427	SCREW #12 X 5/8 [4 EA]
50	2385110	INSULATOR PAD, EM
■	2994856	BAG ASSY (CONTAINS 38-41,32,28,29,47, 50, & TIE WRAPS)

